



Square
Bear

FREE YOUR MIND

WELLBEING IN THE WORKPLACE

Creating a healthy workplace plays an important and active role in maintaining mental health and well-being that results in benefits for both employer and employee. A well designed workplace supports individual work styles and leads to a reduction in absenteeism, increased employee engagement, and improved productivity. These important factors create positive organisational culture and a successful business outcome.

Reducing mental strain assists to protect against negative factors that impact on an individual's performance. Treating employee health as a primary consideration of business operations creates a work environment of happier healthier employees, and supports the engagement of a productive workforce.





SQUARE BEAR

Square Bear is committed to creating products that increase a state of well-being. We are an Australian owned business, and our product designs support the need for work environments that allow people to think, focus, find mental peace, and support physical mobility and movement. Ultimately, we aim to increase productivity by supporting biophilic design styles for the workplace that can enhance employee well-being.

We create unique products to suit a variety of work styles. We focus on designing products that decrease distraction, stress, noise levels, and other negative influences. We understand the benefits of quiet workspaces for both individual and collaborative work styles and the requirement for sustained personal health while at work.

We believe that if you feel better, you work better.

RESEARCH AND DESIGN

Our talented R+D team design products that reflect our core value of enhancing workplace well-being. Our creative design hub and manufacturing facilities sit side by side, allowing our designers to constantly adapt and pursue new ideas that satisfy the ever-changing nature of the workplace. All aspects of production are considered throughout the design process including how the product will be used, how it looks, thoughtful selection of materials, manufacturing requirements, ease of installation and most importantly, the experience for the user.

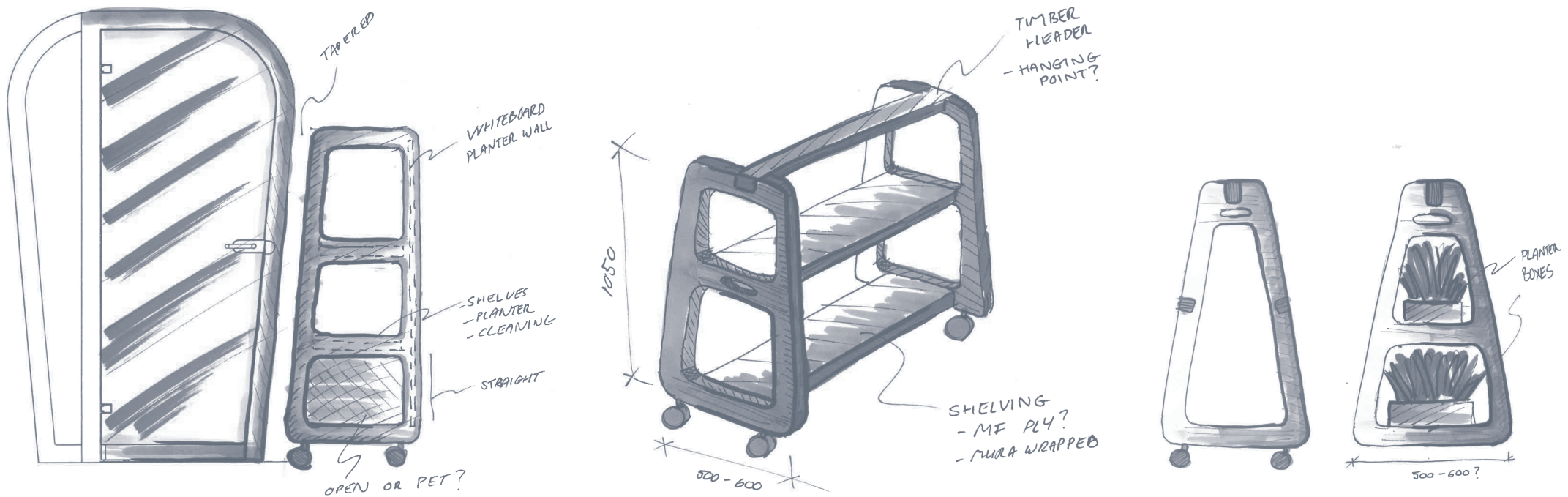

WHY ENHANCE THE WORKPLACE?

Different work styles require different work spaces. Providing options for areas to work on individual and collaborative tasks also provides options for an improvement in focus, output, and satisfaction. Needs vary from person to person, task to task. Square Bear is aware that by creating an environment that offers flexibility, personal requirements can be satisfied, and greater productivity levels will be achieved. Some people like to work in busy environments, some people need to remove themselves from the distraction, and everyone needs a combination of both options for different projects, tasks, and work styles at different times. Square Bear products support task performance for different workstyles, individual preferences, and task requirements.



ACOUSTICS AND PRIVACY

Finding peace in a busy environment can be difficult. Finding peace in a RETREAT pod is easy. Reducing noise can reduce distraction and enhance focus and well-being. Square Bear products aim to reduce work-related stress by offering a quiet space for individuals to retreat into when they need to find peace or privacy. Ideal for one person to escape the noise, or to gain focus for a team meeting and collaborative project, RETREAT provides an option for all quiet-time requirements. The short-term benefits of stress reduction can increase happiness and productivity, the long-term benefits can reduce absenteeism, conflict, and dissatisfaction. RETREAT provides a reduction in noise and an improvement in mental well-being.



OUR PRODUCTS IN THE WORKPLACE

Creating a layout to suit organisational needs considers all aspects of understanding how people interact and perform activities in the workplace. Square Bear products have been designed to provide flexibility. By combining various sizes of the RETREAT pods, a workspace will support meetings of various sizes, quiet work zones, private places for phone calls and thought processing, and a variety of activity areas with mobile whiteboards, bench seats, shelving, and planters. Easily adapted to the day's demands or the task requirements, employees can quickly move from meeting space into break-out zone and back again. RETREAT can be placed together in clusters, against walls, or in open plan areas to form a division between one zone and another. Using mobility and flexibility, employees can focus, meet, collaborate, and recharge their minds with ease.

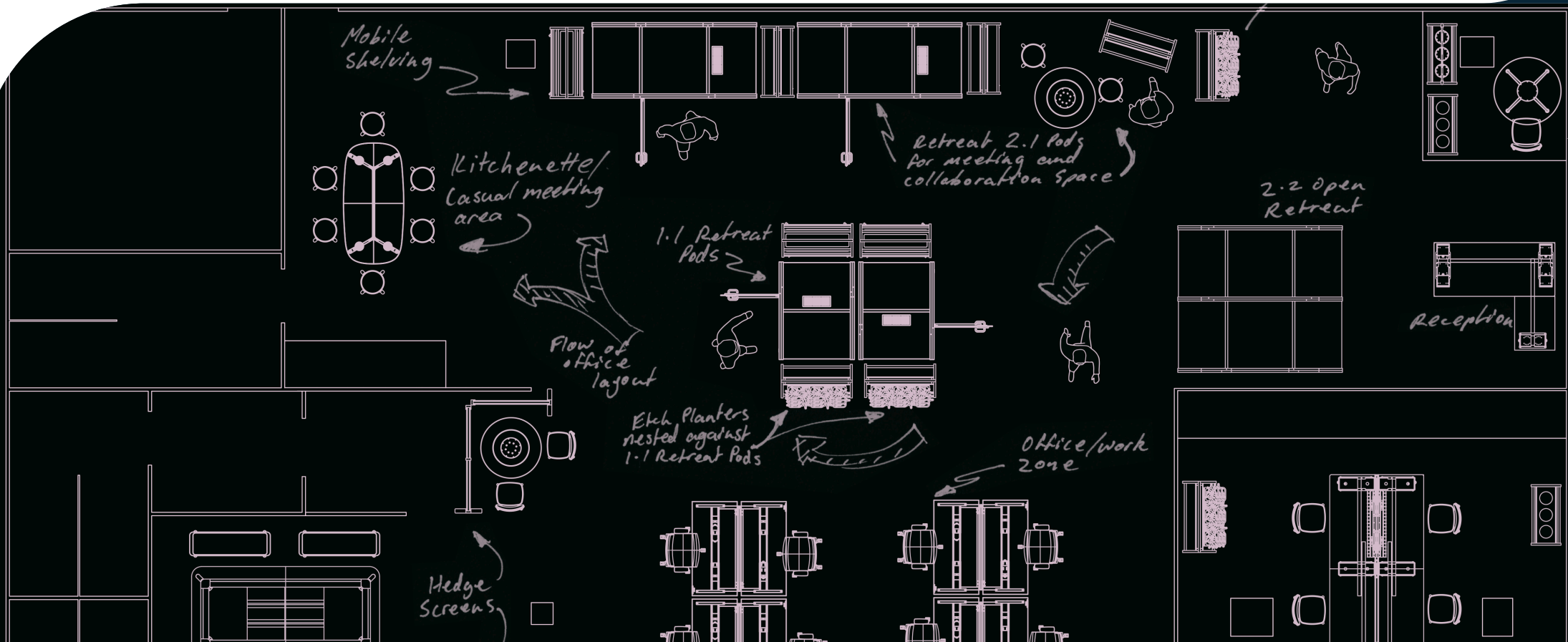



SUSTAINABILITY

We are continually striving to achieve best-practice for social responsibility and environmental policies.

From the selection of materials to our supply chain choices, to understanding energy efficiency and making an investment in respectful social choices, we aim for transparent communication, good judgement, and the role of taking responsibility for developing a better world.

Square Bear works with an independent consultant to obtain appropriate certification and is dedicated to complying with environmental standards and meeting human rights best practice. We are currently in the process of becoming a signatory to the UN Global Compact to demonstrate our commitment to address human rights, labour rights, environmental compliance, and anti-corruption.

Supply-chain due diligence is carried out for all components of production and is continually reviewed for updates. Square Bear implement ethical decision making for the benefit of all stakeholders while making a commitment to continually review and improve processes, production, and strategic direction.

We plan to act responsibly and to be transparent in all our sustainability communication.



PRODUCT RANGE



RETREAT

This innovative private workspace is designed with an ergonomic tapered form inspired by the contour of the human body to give you more head space to breath, think, and work in peace.

Each product allows for modular design and is finished to a high standard using environmentally sourced materials. Acoustic materials are used both on the inside and outside of RETREAT pods, with additional acoustic baffles in between the walls to maximise acoustic performance. Highly functional, exceptionally comfortable, and acoustically private, RETREAT suits any workplace layout to provide quiet workspaces and unique structure. RETREAT comes without a floor base to allow for all users to enter the space without hinderance.

Dual vents and fans circulate air throughout RETREAT from both the base and top. This allows for an increase in oxygen availability to maximise comfort for the user. The fans and a light sensor are automatically controlled on entry and exit of the pod.

All enclosed RETREAT pods provide internal power and data options for a fully integrated plug and play solution, USB A and/or C ports are available on request. Depending on building and fire regulation requirements, RETREAT has been designed to provide access for a sprinkler system, smoke detector and alarm to be installed in coordination with individual project engineering specifications. This option can be linked to mechanical services within the workplace.

RETREAT is available with a rear glass panel, printed glass or full PET back on all models.

KEY FEATURES

Square Bear products are manufactured using high quality materials that are sustainable and ethically sourced. All materials are selected based on their suitability for structural and aesthetic requirements with as much local content as possible. Frames, door handles, hinges, glazing and the castors on accessory items are all tested for strength and durability to ensure product longevity.

 **VENTILATION**
Low noise, sensor-controlled ventilation system with constant air exchange via top and base outlets with internal fan systems.

 **INSTALLATION**
RETREAT 1.1 requires 2 men for 2-3 hours.
RETREAT 2.1 requires 2 men for 3-4 hours.
RETREAT 2.2 requires 2 men for 4-5 hours.

 **SERVICES**
Seamless mechanical services integration with allowances for sprinklers and smoke detector.

 **PLUG AND PLAY**
Quick connection to mains power using standard sockets.

 **PERFORMANCE**
Acoustic materials used for internal and external surfaces provide ambient noise reduction and minimise noise reverberation from the surrounding office.

 **ACCESS**
RETREAT sits flush on the floor with a rubber seal for acoustic protection, there is no step or floor base to impede entry.

 **ENVIRONMENTAL DATA**
60% recycled content to PET.
Sustainably sourced timber FSC timber available on request.

 **WARRANTY**
5 year structural warranty.



Sensor controlled led lighting



Fold down table



Fixed table



Stainless steel magnet door latch

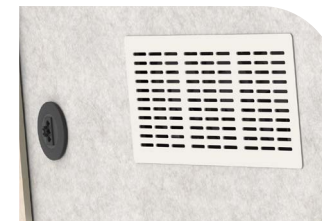

Ventilation and plug & play outlet



Integrated technology and power



Sealed base, sits flush on the floor with acoustic rubber seals, no floor base or step, meeting DDA requirements

FINISHES

Square Bear products are available in a range of standard and seasonal finishes. Seasonal finishes are subject to availability and current design trends. Custom options can be quoted on request including digital printing for internal and external faces of the RETREAT pods.

The internal seating products for RETREAT include sofas and stools that are available in our standard fabric upholstery range. Custom finishes can be quoted on request.

Table finishes

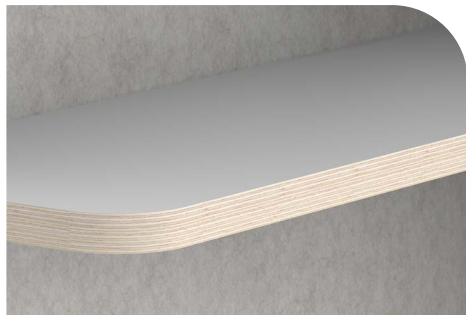

White melamine with natural plywood edge

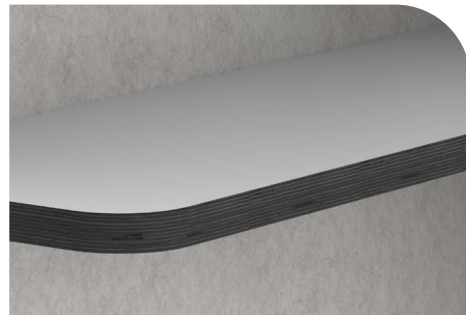

White melamine with black stain plywood edge

Timber finishes



Natural

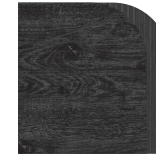

Black Stain

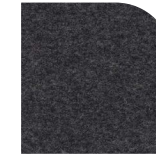

Blazer Silcoates

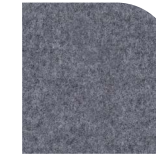

Blazer Surrey

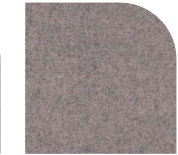

Blazer St Andrews

Sofa and stool upholstery finishes

Acoustic panel standard finishes



Silica Beige 454



Dune Beige 402



Boulder Grey 442

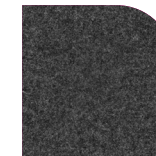

Granite Grey 452



Slate Blue 365

Acoustic panel seasonal finishes



Dulcie 908

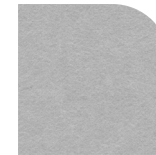

Welford 101



Otway 458



Davenport 444



Cape Byron 577



Eyre 487



Ruby Gap 269



Wollumbin 550



Grampian 349



Daintree 330

RETREAT 1.1

Designed for one person to work in, or two for a quick chat, RETREAT 1.1 is manufactured using sustainable timber frames and acoustic fabric panels in a range of colour combinations. Table-top options are available for either a fixed or drop down version, and an inbuilt light with sensor controlled LED provides energy efficiency.

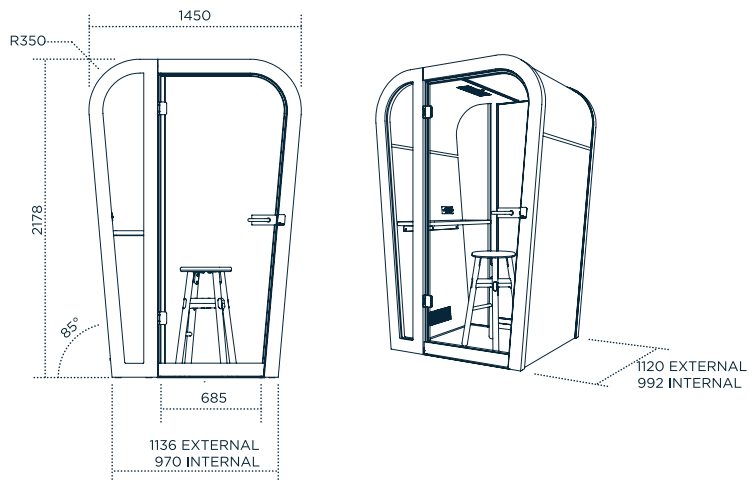

RETREAT 2.1

RETREAT 2.1 is perfect for a small meeting or collaborative workspace. Providing room for up to four people, RETREAT 2.1 is designed for task meetings, private conversations, and a place to escape the busy work environment. Quick to install, the 2.1 workspace is ideal for any workplace setting.

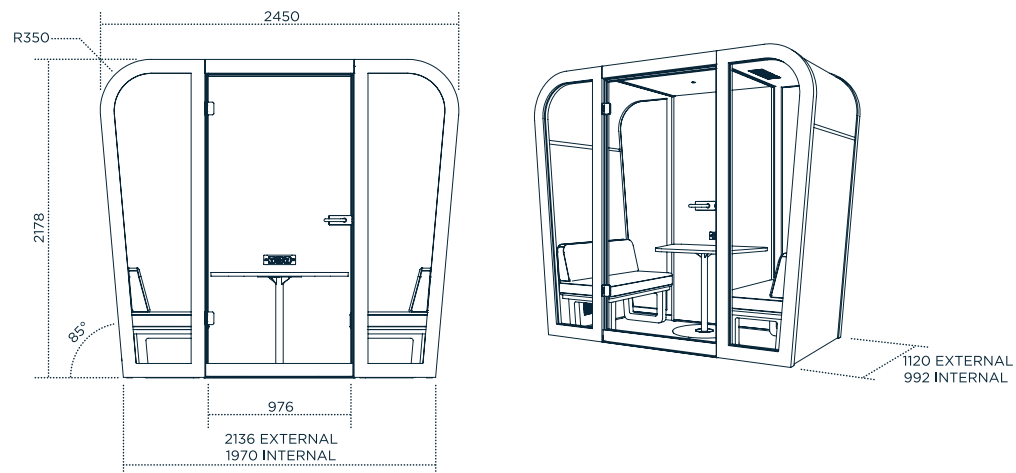

RETREAT 2.2

RETREAT 2.2 is ideal for large meetings and collaborative tasks when more space is required. RETREAT 2.2 can accommodate various furniture styles, configurations, and integrated AV and IT options.

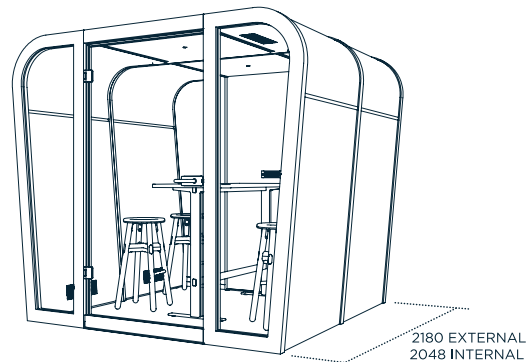
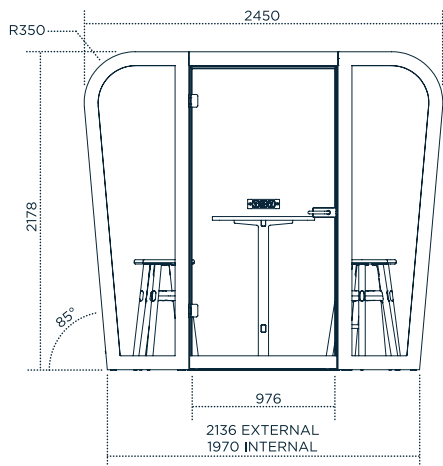

OPEN RETREAT

Providing a space to escape without the formality of a meeting room, OPEN RETREAT can integrate into workplace designs as an additional meeting zone, quiet space, or for team-work.

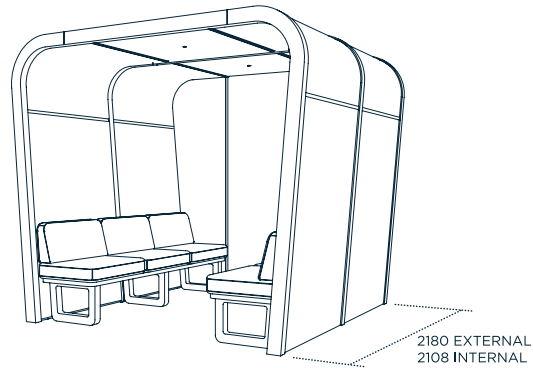
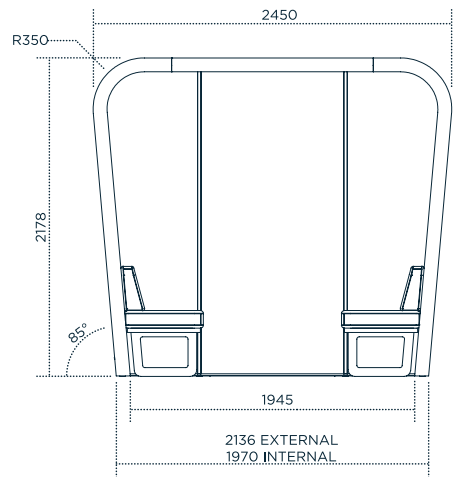

FURNITURE AND ACCESSORIES

RETREAT has a complementary range of furniture options designed and manufactured by Square Bear. A fixed or fold-down table option is available in RETREAT 1.1, and for the larger RETREAT 2.1 and RETREAT 2.2 freestanding tables and sofas are available in standard or custom finishes. Furniture styles can be adapted to suits various options for standing or seated requirements.

Square Bear also have a range of accessory products to enhance and support a calm, varied, workspace. The 100 ACRE planters provide green-walls, décor, and screening, all on castors for easy mobility within the work environment. ETCH is a mobile whiteboard available in a range of surface combinations or as a shelving unit. BENCH can be a planter unit or a moveable seat making it ideal for breakout meetings. All accessory products nest neatly between the RETREAT pods, providing mobile flexible furniture for all workspaces.

Tables



1.1 Fixed table



1.1 Fold down table



2.1 Centre table high or low



2.2 Meeting table high or low

Seating



2.1 Sofa



2.2 Sofa



Okidoki high stool

Accessories



2.2 Whiteboard

ETCH

ETCH is a mobile whiteboard with multiple surface options including whiteboard, pinboards and shelves for a flexible, productive work environment. The tapered design of ETCH complements the RETREAT product range and nests neatly in between pods when not in use.

ETCH is available in a variety of combinations including:

- Magnetic Whiteboard
- Pinboard
- Half Whiteboard / Pinboard
- Half Whiteboard / Cantilevered Planter
- Half Pinboard / Cantilevered Planter
- Full Cantilevered Planter

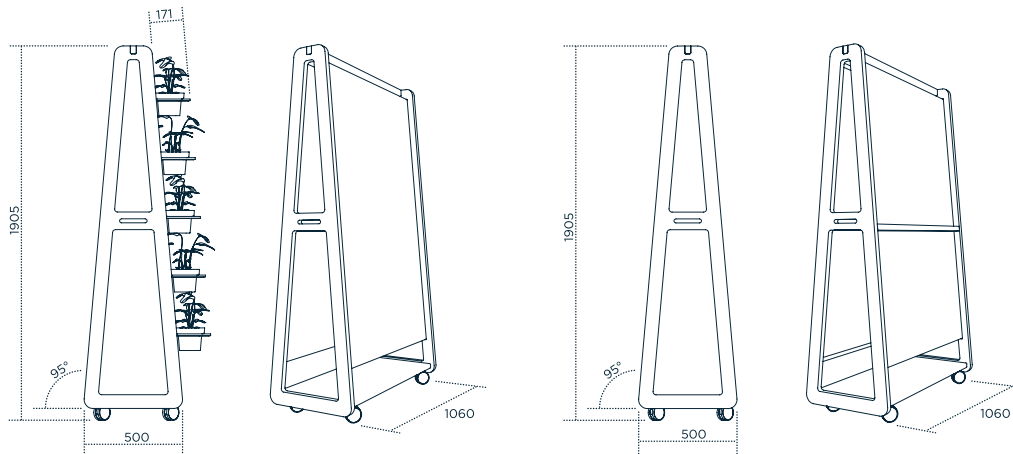

100 ACRE PLANTER

Greenery can be added to the work environment in a functional way using 100 ACRE. With mobile locking castors and optional finishes, 100 ACRE PLANTER provides natural enhancement within the workplace, and a mobile green wall that can be used for aesthetics or as a divider between work areas.

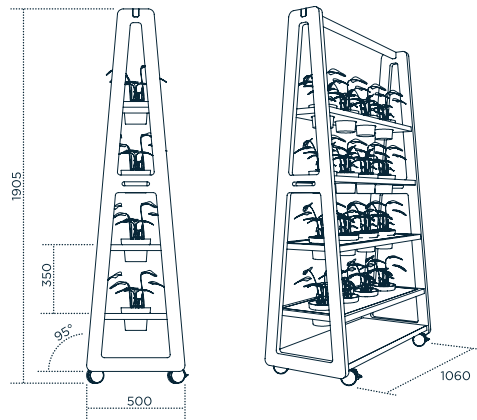

100 ACRE TRELLIS

Adding a green wall without the need for a structural component, 100 ACRE TRELLIS can move around the office to create a privacy barrier, a separate working area, décor, change of scene, or living sculpture.

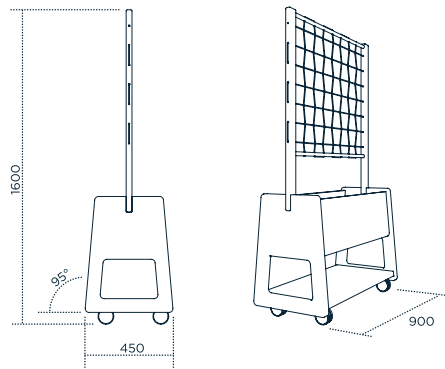

100 ACRE SHELF

100 ACRE SHELF can be used as a mobile library, dividing wall or reference point, and stores neatly in between RETREAT pods. Mobile lockable castors provide the mobility and flexibility to change the office layout or break-out requirements on demand. Available in standard finishes and custom finishes on request.

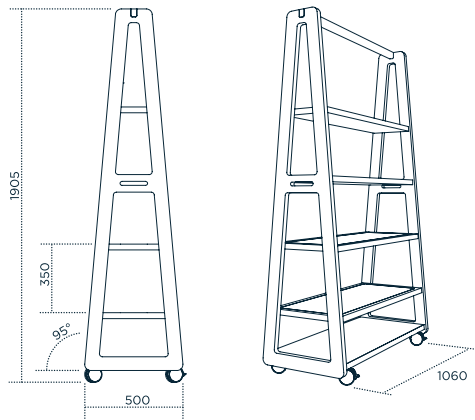

BENCH SEAT AND PLANTER

BENCH is available in two options, as BENCH SEAT and BENCH PLANTER. This mobile product is easily moved and can be used for additional seating when an impromptu meeting occurs, or as an instant privacy barrier for a meeting within an open plan environment. Enhancing the workspace with greenery adds to the well-being of employees and provides a natural aesthetic. BENCH nests in between RETREAT pods and can be moved as required.

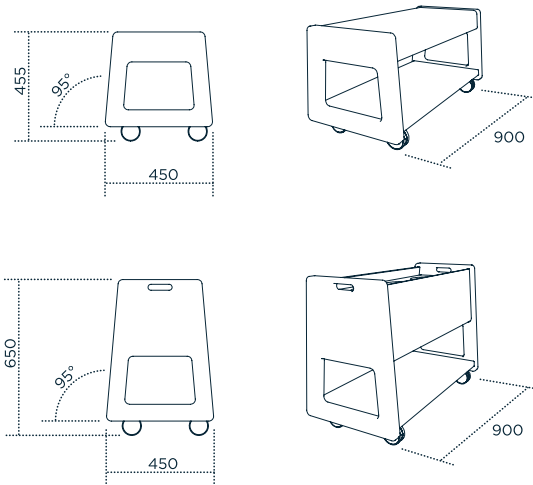

HEDGE

HEDGE provides a versatile semi-static visual and acoustic barrier for privacy without disturbing the office layout. Easily moved, HEDGE can be adapted to suit a variety of work styles including private or collaborative work needs to enhance a flexible work environment.

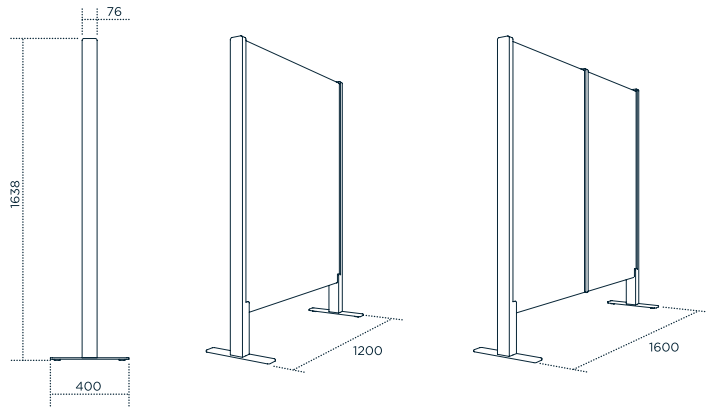

SQUARE BEAR

© Copyright 2021

All Rights Reserved

HEAD OFFICE

Unit 6/80 Jemma Road, Prestons

New South Wales 2170, Australia

P: +61 (0)2 9189 1444

sales@square-bear.com

SYDNEY SHOWROOM

120 Bourke Street, Woolloomooloo

New South Wales 2011, Australia

www.square-bear.com



**Square
Bear**

FREE YOUR MIND